

0 601 216 1FK – GSB 450

Material number	0 601 216 1FK
EAN	3165140939928



Technical data

Technical data

Rated input power	450 W
No-load speed, 1st gear	0 rpm
Power output	250 W
Weight	1.5 kg
Drill spindle connecting thread	3/8"-24 UNF
Chuck capacity, min./max.	1.5 – 10 mm
Tool dimensions (width)	69 mm
Tool dimensions (length)	262 mm
Tool dimensions (height)	180 mm
Impact rate at no-load speed	0 bpm
Drill chuck, version	Keyed chuck
Voltage, electrical	220–230 V

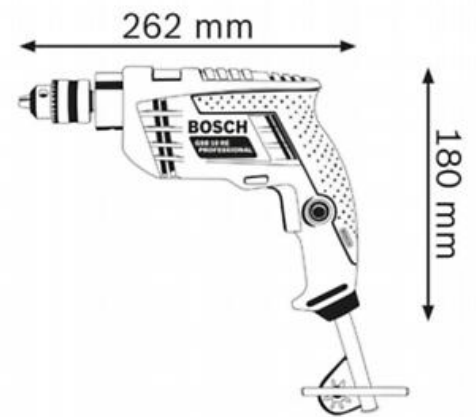

Drilling range

Drilling diameter in concrete	10 mm
Drilling diameter in wood	20 mm
Drilling diameter in steel	8 mm

Noise/vibration information

Noise level	The A-rated noise level of the power tool is typically as follows: Sound pressure level dB(A); Sound power level dB(A). Uncertainty K= dB.
-------------	--

Sales information

Positioning

- Compactness and power redefined in this class

User benefit

- Robust and powerful 500 W motor
- Extremely compact for working in tight spaces and overhead
- Low weight of only 1.5 kg for fatigue-free working

